



KLY-489BSW

USER MANUAL

| | |
|---------------------------|----|
| Technical parameter..... | 1 |
| Control panel..... | 4 |
| DMX Channel..... | 13 |
| Dimensional drawing..... | 17 |
| Routine maintenance..... | 18 |
| Fault handling..... | 19 |
| Safety information..... | 20 |
| Luminaire connection..... | 21 |

1/Technical parameter

| Technical parameter | |
|---------------------|----------------------------------------------------|
| AC power | 100~240V AC, 50/60Hz |
| Rated power | 600W@220V |
| Lamp | 400W LED |
| Rated life | 20000h |
| LUX | 5m 127000LX |
| Beam Angle | 3°~45° |
| Color temperature | 7000K |
| Angle of rotation | Horizontal scanning 540° Vertical scanning 270° |
| Shutter | 0~30HZ |
| colour | 1 Color Plate (8 colors + White light), CMY, CTO |
| pattern | 1 Fixed Pattern Plate (12 patterns + White light) |
| | 7 rotating pattern |
| Prism | 8 prism + single six row prism |
| dimming | 0-100% linear adjustment |

| | |
|-------------------------|-------------------------------------------------------------------------------------------------------------|
| Frost | 0-100% linear adjustment |
| Focus | DMX linear adjustment |
| Control and Programming | DMX512,RDM, master/slave synchronous control mode, self-walking mode, voice control mode, single scene mode |
| Channel | 22CH/26CH |
| Protection rating | IP20 |
| Housing | High temperature resistant flame retardant plastics |
| AC power in/thru | Neutrik PowerCon |
| DMX data in/out | 3-pin locking XLR |
| Weight | 24kg |
| ambient temperature | -20°C~40°C |
| Lamp size | 380x274x665mm |
| package size | 750×360×465mm |
| Standard arrangement | Power cord 1PCS, safety rope 1PCS,DMX signal cable 1PCS, integrated folding light hook 1PCS |

Fixed pattern

Rotating pattern



Illuminance

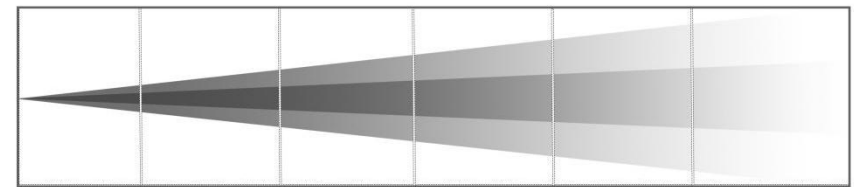

Beam Mode

| distance(M) | 5 | 10 | 15 | 20 | 25 |
|-------------------|--------|-------|-------|-------|------|
| illumination(LX) | 127000 | 39000 | 14000 | 10500 | 7900 |
| Spot diameter(CM) | Ø34 | Ø53 | Ø80 | Ø107 | Ø140 |

Gobo Mode

| distance(M) | 5 | 10 | 15 | 20 | 25 |
|-------------------|--------|-------|-------|-------|------|
| illumination(LX) | 127000 | 39000 | 14000 | 10500 | 7900 |
| Spot diameter(CM) | Ø47 | Ø88 | Ø134 | Ø187 | Ø220 |

Color plate/pattern plate



2/Control panel



The schematic diagram of the lamp panel is shown in the figure. The title above shows the name of the lamp, while the status bar below shows the signal, bulb status and fault of the current lamp ("ERR" is displayed when failure information is not checked, or "NOR" is displayed).

The lamp supports DMX/RDM protocol. When the lamp is searched by the RDM host, three letters "RDM" will appear on the panel, indicating that the lamp is enumerated normally.

The display and operation is similar to "Android operating system", which can be operated by clicking corresponding items with fingertips or blunt objects.

⚠ Note: Do not use sharp or sharp objects to click the display, in case of damage.

Display window function control

- Operate luminaire using intuitive touch or auxiliary input (touch enabled products)
- The left area is the TFT display area and the touch area. You can click the contents of the panel with your finger or blunt surface hardware to set parameters or view the status.

- The right area is auxiliary input. If you do not use the touch function of the TFT, you can use the auxiliary input to select the items to be set or viewed

1. Parameter value input

When the selected parameter needs to enter a value, the window as shown in the figure will open:

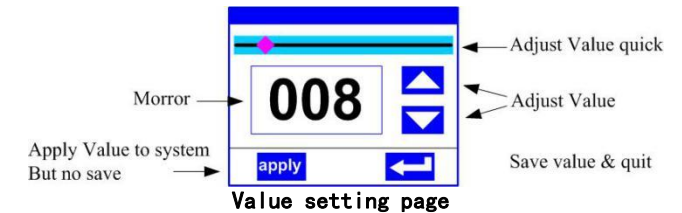

- **set numerical:** can directly pull the slider quickly set up the required value, can also click the "on" or "down" button on the right precise numerical or supplemental input set required Settings.
- **Applied value:** When the data is set by "up" or "down" button, then press the "apply" key in the lower left corner, the value is immediately sent to the lamp, but the value is not saved.
- **Save value:** At any time, click the "OK" key in the lower right corner, that is, to save the current value to the internal storage, the next startup to save the value applied to the lamp.
- Set Boolean parameters
- when setting the parameters for Boolean values (such as ON or OFF), the switch directly click ON the corresponding item parameter value, the parameters of the modified will be saved to the internal storage. Press the parameter option on the right and the corresponding option will be grayed out. When the hand is released, the corresponding parameters are changed and saved. If pressing the parameter option is not the parameter you want to change, you can move your finger to another part of the screen and the corresponding parameter will not change.

important determine through Boolean parameters, determine the window to set, as shown in the figure below:



Subpage (parameter)



Figure 6-1

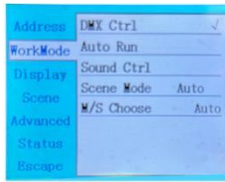

Figure 6-2

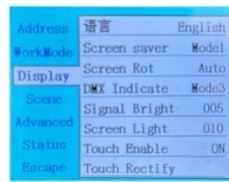

Figure 6-3



Figure 6-4

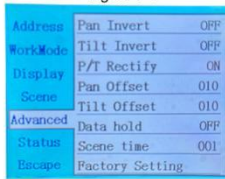

Figure 6-5

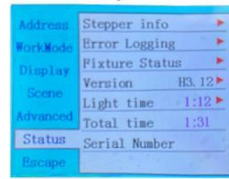

Figure 6-6

1. Functional operation and parameter setting

- In the main interface, you can enter the corresponding parameter setting interface by selecting six buttons.
- In the parameter setting interface, you can press the left blue option to quickly switch to the other setting interfaces.

1. Set up the DMX address code

The DMX address and channel mode of the lamp can be set on the page as shown in Figure 6-1.

The menu setting of the lamp optimizes the setting of the address, and the address code operation is as follows:

- Select "Last" or "Next", the lamp will automatically calculate based on the current address code and channel dataOne or the last one of the address code, you can quickly set;
- click the address code number, can enter the numerical editor window, here you can set the address code of any effective, automatic access to the current channel number of lamps and lanterns of lamps and lanterns, automatic filter do not use the address code (512 - the current channel number).
- support RDM protocol of lamps and lanterns, lamps and lanterns can be set by RDM remote address code.
- Two buttons are provided:
- Channel mode: Different channel modes can be selected cyclically.
- reset of lamps and lanterns: reset all motors.

2. Set the working mode of the lamp

Set the running mode of the lamp, as shown in Figure 6-2. The lamp supports four operating

modes (DMX mode, self-propelled mode, voice-controlled mode and scene mode). Please refer to the previous section for detailed parameter setting. The specific parameter description is shown in the following table:

operational mode

| | | |
|--------------------|-----------------------------------------------------------------------------------------------------------------------------------------------------------|------------------------------------------------------------------------------------------------------------------------|
| DMX mode | Console mode, receiving the DMX signal, and the RDM signal | |
| Self-walking mode | The lamp runs automatically according to the built-in program | |
| Sound control mode | When the lamp detects a strong sound, the lamp automatically runs a scene according to the built-in program, otherwise maintain the last scene | |
| Scene mode 01 | The above set scenario runs in the same mode and supports custom editing of up to 10 scenes | |
| | 1~10 | Outputs the specified scene |
| | automatic | Automatically output the scene in the set scene time (non-0) order, and the scene with time 0 is automatically skipped |
| Master from choice | When non-DMX mode, select the data output mode, the lamp automatically detects the DMX state and automatically switch the output to prevent data conflict | |
| | master | The lamp runs as built-in, if DMX has no signal, output data (synchronization), otherwise no data output |
| | slave | Lamp operate as built-in, no output data (not synchronized with other lamps) |
| | Auto | If the DMX has no signal, the lamp operates as built in, otherwise, the lamp works with the DMX signal |

Scene mode is suitable for a single set or a small number of lamps, only need to output a fixed scene, or need to run a simple program, can be edited in the scene page without connecting the console.

If the light source is a bulb, wait 10 minutes before turning the bulb turned off.

3. Panel display settings

The lamps support Both Chinese and English, inverted display, etc. Enter the corresponding parameter setting as shown in Figure 6-3. The specific menu contents are shown in the following table:

Display settings

| | | |
|----------------------|---------------------------------------------------------------------------------------------------|-------------------------------------------------------------------------------------------|
| language | Set up the language of the display | |
| | English | English display |
| | Chinese | Chinese display |
| Screen protection | Set the display content or mode of the screen after the screen has no operation within 30 seconds | |
| | close | Keep the last operation page up and light up the screen |
| | Mode 1 | Out of the screen |
| | Mode 2 | Black screen, showing the address code of the current lamp in the lower left corner |
| | Mode 3 | Displays the trademark information, address code and operation mode |
| Screen rotation | Set the display direction of the screen | |
| | close | No reversal is shown |
| | open | Reverse display |
| | Auto | Automatically detect the direction of lamp and automatically switch the display direction |
| DMX indicate | Set the indication mode of the DMX signal indicator light | |
| | Mode 1 | When the signal is bright, and when there is no signal, go out |
| | Mode 2 | Out when signal, bright when no signal |
| | Mode 3 | Blink when signal, extinguish when no signal |
| The signal indicates | Set the brightness of the signal indicator light | |
| | 1~10 | Ten grades |

| | | |
|---------------------|-------------------------------------------------------------------------------------------------------------------------------------------------------------|------------|
| brightness | | |
| Screen backlight | Set the brightness of the screen backlight after 10 seconds of no operation, full bright during operation | |
| | 1~10 | Ten grades |
| Touch screen switch | Select whether to disable the touch screen. When the screen touch is accidentally damaged, disable the touch function and set the lamp with auxiliary input | |
| Touch correction | When the screen touch is not accurate, you can enter the correction page correction screen | |

Lamps that support touch operation. If the bad touch phenomenon occurs, you can enter the correction page to reset the touch accuracy of the touch screen. Under normal circumstances, please do not enter this page. If the touch is damaged, select to disable the touch switch.

4. Scene mode

Entering the page, the lamp enters the scene editing mode. Under this page, the lamp does not receive the DMX console data, and the edited data is immediately reflected on the lamp.

The content of the page depends on the currently selected channel, and the channel content and order displayed are consistent with the lamp channel table. Through this page, 10 scenes can be edited, as shown in the following table:

Scene mode

| | | |
|--------------------|-------------------------------------------------------------|--------------|
| Scenario selection | Select the current required action scenario | |
| | 1~10 | 10 scenarios |
| Scene time | Sets the retention time of the current scene in 0.1 seconds | |

| | | |
|-------------|-------|------------------------------------------------------------------------------------------------------------|
| | 0 | The current scene does not participate in the automatic scene output |
| | 1-255 | 0..1s thru 25.5s |
| 1. pan | 0-255 | Set the data of each channel, the display content and sequence correspond to the channel table of the lamp |
| | 0-255 | |
| | 0-255 | |
| N. function | 0-255 | |

If the effective reset data is edited in the reset channel in the scene, the lamp will reset, but after reset, the value of the corresponding reset channel will automatically reset to prevent multiple consecutive reset.

On this page, you can get the current channel table order of the lamp. Please refer to the detailed channel description for the specific channel data.

5. Set the working parameters of the lamp

Enter the page shown in Figure 6-5, adjust the field parameters of lamps, and facilitate the field installation of lamps:

advanced setup

| | | |
|-------------|-----------------------------------------------------|-----------------------------------------------------------------------------------|
| Pan Invert | Set the X-axis rotation direction | |
| | OFF | Don't reverse |
| | ON | reverse |
| Tilt Invert | Set the Y-axis rotation direction | |
| | OFF | Don't reverse |
| | ON | reverse |
| P/T Rectify | Set whether the lamp detects XY misstep and correct | |
| | OFF | Position is not corrected after the misstep |
| | ON | Automatic correct the position after the lost step and record the lost step fault |
| Pan Offset | Set the position of the lamp | |

| | | |
|-----------------|----------------------------------------------------------------------------------------------------------|----------------------------------------------------------------------------------------------------------|
| | 4-150 | |
| Tilt Offset | Set the position of the Y axis of the lamp | |
| | 4-48 | |
| Data hold | Set the output status of the lamp when the lamp has no DMX signal | |
| | OFF | No signal, so the motor and the light source return to the position and state when the reset is complete |
| | ON | No signal, keeping the last frame of the DMX data output |
| Factory Setting | The confirmation box pops up. After selecting "SURE", the lamp parameters return to the factory settings | |

When the lamp cannot correct the position, first check whether the optical coupling correction is closed.

When the signal is removed, if the lamp position is not output as intended, check the Data Hold setting first.

When setting the XY offset, after completing the setting, please control the XY with the maximum stroke to check the setting, XY will not hit the positioning rod.

6. View the current status of the lamp

Entering the page shown in Figure 6-6, you can view the information and real-time status of the lamps to know the use status of the lamps. If the lamps need an after-sales service, please provide the status information displayed on the page as the judgment basis, as shown in the following table:

status information

| | | |
|-----------------------|-------------------------------------------------------------------------------------------------------------------------------------------------------|----------------------------------------------------------------------------------------------------------------------------------------------------------------------|
| Stepper info | Display the information status of all the motors and signals in the lamp | |
| | Hoare | Not shown, means the motor has not Hall corrected, 0 means the motor leaves the correction position point, and 1 means the motor is at the correction position point |
| | status | Show the motor reset completion state |
| | Pan | Displays the real-time position value of the X-axis optical coupling feedback |
| | Tilt | Display the real-time position value of the Y-axis optical coupling feedback |
| | optocoupler | Show the level state of two signals with X and Y axis, binary |
| Error Logging | Display the last 8 fault records of lamp reset and operation, the fault records are not saved after power failure, when the next power cycle is valid | |
| | Fault data | Total number of faults detected after power-on |
| | 12: :03 | Power time in minutes |
| | Hall fault | The corresponding motor does not detect an effective Hall signal when the motor is reset |
| | Hall short circuit | The Hall signal of the motor detected at the corresponding motor reset is always valid |
| | Optical coupling failure | No effective photocoupling signal is detected when the corresponding motor is reset |
| | fall out step | The corresponding motor loses its step during operation |
| | Crash rod | Cragainst the positioning lever when the motor is reset |
| | Bulb failure | Light bulb accidentally extinguished |
| | Sensor failure | Temperature sensor signal is abnormal |
| | Fan fault | The main fan is not working properly |
| Fixture Status | Displays the critical status data for the current lamp for reference | |
| | communication | 0~100%, the communication quality of the data link |

| | | |
|-------------------|--------------------------------------------------------------------------------------------------------------------|------------------------------------------------------------------------------------------------------------------|
| | | within the lamp |
| | miscount | The number of error frames detected after power, accumulated |
| | Light source temperature | Show the temperature of the current light source, "--" indicates no detection |
| | Display plate temperature | Displays the temperature of the current display board or the nearby ambient temperature |
| | Sensor 1 temperature | Displays the current motherboard temperature or the ambient temperature at the motherboard installation location |
| Version | Display the information and version of current lamps and an important reference for after-sales maintenance | |
| | equipment | Name of lamp, same to equipment information of RDM |
| | model | Model of lamp, same as model information of RDM |
| | display panel | Firmware version and serial number of the display board |
| | motherboard 1 | Firmware version and serial number of the motherboard 1 |
| Light time | Record the total accumulative time of the light source, as a reference for regular maintenance of the light source | |
| Total time | Record the total cumulative time of lamp opening, unit minutes, do not clear | |

3/DMX Channel

DMX Channel 22CH/26CH

| 26CH | 22CH | function | numerical value | describe |
|---------|----------------------------------------------|-----------|-----------------|----------------------------------------------|
| 1 | 1 | Pan | 0-255 | 0-540° |
| 2 | 2 | Pan fine | 0-255 | 0-2° |
| 3 | 3 | Tilt | 0-255 | 0-270° |
| 4 | 4 | Tilt fine | 0-255 | 0-1° |
| 5 | | XY speed | 0-255 | From fast to slow |
| 6 | 5 | Dimmer | 0-255 | With 0-100% dimming |
| 7 | 6 | Shutter | 0-3 | Close |
| | | | 4-103 | From slow to fast pulse frequency strobe |
| | | | 104-107 | on-off |
| | | | 108-155 | From slow to fast |
| | | | 156-207 | From slow to fast to random frequency strobe |
| | | | 208-212 | on-off |
| 213-251 | From slow to fast to random frequency strobe | | | |

| | | | | |
|---------|--------------|---------------|---------|----------------------------------------------|
| | | | 252-255 | on-off |
| 8 | 7 | Color | 0-9 | White |
| | | | 10-19 | Red |
| | | | 20-29 | Orange |
| | | | 30-39 | Yellow |
| | | | 40-49 | Green |
| | | | 50-59 | Cyan |
| | | | 60-69 | Pink |
| | | | 70-79 | Magenta |
| | | | 80-89 | Blue |
| | | | 90-99 | White+Red |
| | | | 100-109 | Red+Orange |
| | | | 110-119 | Orange+Yellow |
| | | | 120-129 | Yellow+Green |
| | | | 130-139 | Green+Cyan |
| | | | 140-149 | Cyan+Pink |
| | | | 150-159 | Pink+Magenta |
| 160-169 | Magenta+Blue | | | |
| 170-179 | Blue+CTO | | | |
| | | | 180-215 | From fast to slow forward flowing water |
| | | | 216-220 | Stop |
| | | | 221-255 | From slow to fast, the reverse flow of water |
| 9 | 8 | Cyan | 0-255 | |
| 10 | 9 | Magenta | 0-255 | |
| 11 | 10 | Yellow | 0-255 | |
| 12 | 11 | CTO | 0-255 | |
| 13 | 12 | Fixed pattern | 0-4 | Gobo1 |
| | | | 5-9 | Gobo2 |

| | | | | |
|----|----|------------------|---------|-----------------------------------------|
| | | | 10-14 | Gobo3 |
| | | | 15-19 | Gobo4 |
| | | | 20-24 | Gobo5 |
| | | | 25-29 | Gobo6 |
| | | | 30-34 | Gobo7 |
| | | | 35-39 | Gobo8 |
| | | | 40-44 | Gobo9 |
| | | | 45-49 | Gobo10 |
| | | | 50-54 | Gobo11 |
| | | | 55-59 | Gobo12 |
| | | | 60-64 | White |
| | | | 65-69 | From slow to fast jitter pattern 2 |
| | | | 70-74 | From slow to fast jitter pattern3 |
| | | | 75-79 | From slow to fast jitter pattern4 |
| | | | 80-84 | From slow to fast jitter pattern5 |
| | | | 85-89 | From slow to fast jitter pattern6 |
| | | | 90-94 | From slow to fast jitter pattern7 |
| | | | 95-99 | From slow to fast jitter pattern8 |
| | | | 100-104 | From slow to fast jitter pattern9 |
| | | | 105-109 | From slow to fast jitter pattern10 |
| | | | 110-114 | From slow to fast jitter pattern11 |
| | | | 115-119 | From slow to fast jitter pattern12 |
| | | | 120-127 | White |
| | | | 128-190 | From fast to slow reverse flow water |
| | | | 191-192 | Stop |
| | | | 193-255 | From slow to fast forward flowing water |
| 14 | 13 | Rotation pattern | 0-9 | White |
| | | | 10-19 | Gobo1 |
| | | | 20-29 | Gobo2 |

| | | | | |
|----|----|---------------------------|---------|----------------------------------------------|
| | | | 30-39 | Gobo3 |
| | | | 40-49 | Gobo4 |
| | | | 50-59 | Gobo5 |
| | | | 60-69 | Gobo6 |
| | | | 70-79 | Gobo7 |
| | | | 80-89 | From slow to fast jitter pattern 1 |
| | | | 90-99 | From slow to fast jitter pattern 2 |
| | | | 100-109 | From slow to fast jitter pattern 3 |
| | | | 110-119 | From slow to fast jitter pattern 4 |
| | | | 120-129 | From slow to fast jitter pattern 5 |
| | | | 130-139 | From slow to fast jitter pattern 6 |
| | | | 140-149 | From slow to fast jitter pattern 7 |
| | | | 150-200 | From fast to slow forward flowing water |
| | | | 201-205 | Stop |
| | | | 206-255 | From slow to fast, the reverse flow of water |
| 15 | 14 | Rotation pattern rotation | 0-127 | 0-360° |
| | | | 128-190 | From fast to slow reverse flow water |
| | | | 191-192 | Stop |
| | | | 193-255 | From slow to fast forward flowing water |
| 16 | | Spin pattern fine-tuning | 0-255 | |
| 17 | 15 | Prism 1 | 0-127 | None |
| | | | 128-255 | Open prism 1 |
| 18 | 16 | Prism 1 rotation | 0-127 | 0-360° |
| | | | 128-187 | From fast to slow forward flowing water |
| | | | 188-195 | Stop |
| | | | 196-255 | From slow to fast, the reverse flow of water |

| | | | | |
|----|----|------------------|---------|------------------------------------------------------------|
| 19 | 17 | Prism 2 | 0-127 | None |
| | | | 128-255 | Open prism 2 |
| 20 | 18 | Prism 2 rotation | 0-127 | 0-360° |
| | | | 128-187 | From fast to slow forward flowing water |
| | | | 188-195 | Stop |
| | | | 196-255 | From slow to fast, the reverse flow of water |
| 21 | 19 | Frost | 0-127 | None |
| | | | 128-255 | Open frost |
| 22 | | Auto focus | 0-255 | |
| 23 | 20 | Zoom | 0-255 | |
| 24 | 21 | Focus | 0-255 | From far to near (focus when channel 22 is greater than 0) |
| 25 | | Focus tuning | 0-255 | (focus when channel 22 is greater than 0) |
| 26 | 22 | Reset/ function | 0-209 | None |
| | | | 210-215 | Reset the XY motor after 3 seconds |
| | | | 216-219 | None |
| | | | 220-235 | Return the effect motor after 3 seconds |
| | | | 236-239 | None |
| | | | 240-255 | Return to the whole lamp after 3 seconds |

4/measurement

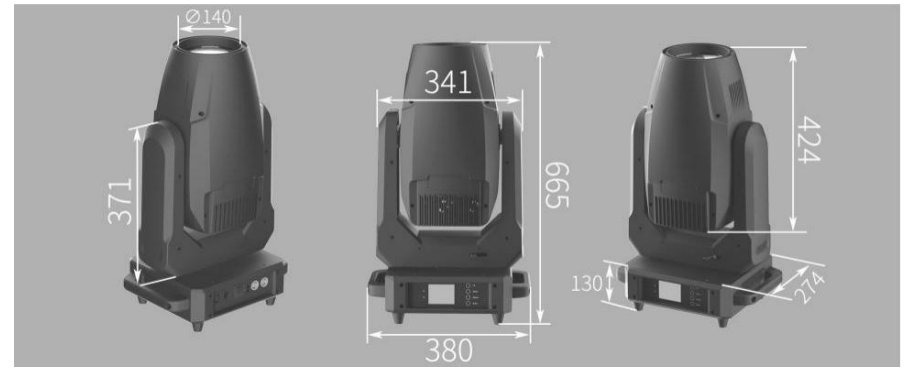

5/Routine maintenance



pay attention to! Excessive dust, smoke flow degree, abnormal damage caused by the use, not within the warranty scope.

warn! Disconnect the power supply before opening any lid.

○ Cleaning

Optical parts should be lightly rubbed, the coating surface is very brittle, very easy to scratch, do not use a destructive solvent, otherwise it will damage the plastic or coating surface.

Note: reset the channel value for 5 seconds.

○ Clean optical elements

1.After breaking off the power supply, cool it down thoroughly and open the lid;

2. Use a vacuum cleaner or a pressure blower to gently blow away the dust and floating objects;
3. Use odorless cotton paper or cotton cloth soaked with water, distilled water to wipe off the particles, do not wipe the surface, and blow away the floating object with pressure gas
4. Use ethylene propylene alcohol-soaked cotton cloth or odorless cotton paper to remove soot and residues, can also use glass cleaning Device, but the residue must be removed with distilled water, wiped from the center to both sides, and then dried with a soft cotton cloth

○ Clean the fan and the air vents

Remove dust from the fan and pores with a soft brush, cotton paper, air vacuum cleaner or pressure hair dryer.

accumulation on the bulbs and other optical components, and the bulbs and the components should be cleaned and maintained regularly.

2. The pattern projection is vague
- Check if the electronic focus channel values are appropriate for the current projection distance.
 3. The light fixtures work intermittently
 Reason: Internal line enters the protection state and handles as follows:
 - Check whether the fan is running normally or whether it is dirty, causing the temperature inside the lamp to rise;
 - Check whether the internal temperature control switch is in a closed state;
 - Check the bulb and replace the new bulb.
 4. The control of the console is not accepted after normal reset

Possible cause: signal line failure or abnormal lamp parameter setting, handled as follows:

- Check the starting address code and the connection of DMX signal line (whether the signal cable is intact and whether the Alcock head connection is loose);
- Add a signal amplifier, add 120 ohm terminal resistance;
 6. The lamps cannot be started
 Possible reasons: Poor power line, treated as follows:
- Check whether the insurance on the power input socket is fused and replace the insurance;
- Poor contact of lamp travel due to vibration in long-distance transportation
- Check the input power supply, computer board and other plug-in devices.

6/fault handling

Lamps contain microcomputer circuit board, high voltage power supply and other professional components, for your safety and product life, non-professionals do not remove lamps and related accessories without authorization.

1. The beam looked dim

Possible reasons: bulb is used long or light path is not clean, treated as follows:

- Check whether the light bulb has reached the service life, and replace it with a new light bulb;
- Check whether the optical components or bulbs are clean, and whether there is dust

7/Security information



All products are well packaged when leaving the factory, please follow the user manual, Machine failure caused by human causes is not covered by the warranty.

- ▲ The light source in this lamp shall be replaced by the manufacturer or its service agent or someone with similar qualifications. If the external soft cable or soft cable of this lamp is damaged, the cable shall be replaced by a qualified person of the manufacturer or its service agent to avoid the danger
- ▲ After receiving the lamp, please open it and check for any damage caused by transportation. Do not use the lamp if it is damaged, and contact the supplier or the manufacturer quickly.
- ▲ This product is suitable for indoor use, its protection grade is IP20, the lamps should be kept clean, avoid use in wet or excessive dust environment, should be maintained once every three months.
- ▲ Only qualified professionals can install, operate and repair the lamps and ensure to operate in strict accordance with the procedures described in this instruction.
- ▲ The lamps shall be installed in a well ventilated place with at least 50CM away from the wall and check the ventilation holes. Do not look directly at the light source to avoid causing damage to the eyes.
- ▲ Please do not turn on the lamps for self-repair.
- ▲ The part of the electrical connection must be operated by qualified installers.
- ▲ Each lamp shall be safely grounded and electrified according to the relevant standards.
- ▲ Do not use the power cord with the damaged insulation layer, and do not attach the power cord on other wires. When the lamp is not used or clean, please unplug the power cord, do not unplug or drag the power cord directly.
- ▲ If the back cover of the lamp is equipped with a safety buckle or connection hole, based on safety reasons, please use the safety rope through the connection hole for auxiliary lifting.
- ▲ There are no parts in the lamp. Before operating the lamp, check whether all the parts are well connected and the screws are reliable and reliable.
- ▲ If you have any doubts, please contact the supplier or manufacturer in time, use the original package to indicate the bad reason to return

8/Lamp connection

Power connection (The power supply and fuse configuration are shown in the

table below)

| Power | fuse |
|------------|-----------|
| 100V-240V~ | T5A, 250V |

If the external soft cable or flexible cable of the lamp is damaged, the soft line shall be replaced with a soft cable or flexible cable specially provided by the manufacturer or its service agent.

The person connecting the power supply must confirm that the power supply voltage used must meet the voltage indicated by the lamp, and must be protected by overload or leakage.



Do not connect too many lamps, or overload the work with a single power cable.

Do not use the power cord with damaged insulation, and do not place the power cord on other wires.

Unplug the power cord when the lamp is not used or clean.

Do not unplug or drag the power cord.

| Wire color | plug | sign |
|--------------|--------------|------|
| brown | Live Wire | L |
| Blue | Neutral wire | N |
| Yellow/Green | Earth | ⊕ |

Signal connection

DMX512 link

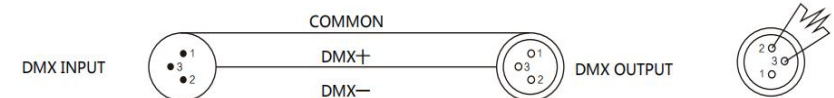

In order to reduce signal errors and avoid signal weakening and interference during transmission, a 120 ohm 1 / 4W resistance can be added between the two and three cores of the DMX output of the last machine.

Connect the lamp with the XLR signal line, one end is connected to the output port of the lamp, and the other end is connected to the input port of the next lamp. Signal lines can only be used in series, not in parallel. Because the DMX512 signal transmission speed is very fast, when the signal line is damaged, the welding place is not strong, the contact is not good, will affect the signal transmission, resulting in the system closed.

When the machine power of a unit is disconnected, the connection between DMX output and input is bypassed to maintain the connection of DMX lines

Each light should have an address code that can receive information from the console.

DMX512 The terminal of the system needs to be equipped with a terminal to reduce errors in signal transmission.

the quality of communication;

RDM use considerations

- RDM is an extended version of DMX512-A protocol, which is the remote device management (Remote Device Management) protocol, traditional DMX512 protocol communication is one-way communication, protocol is based on RS-485 bus, RS-485 is time-sharing multi-point and semi-duplex protocol, only one port is allowed for host output at the same time, so the following points should be noted when using RDM:
 - To use a console or host device that supports the RDM protocol host;
 - To use the two-way signal amplifier, the traditional one-way signal amplifier is not applicable to the RDM protocol, because the RMD protocol needs feedback data, the use of the one-way amplifier will block the returned data, resulting in the search of lamps;
 - When the lamp is subject to DMX control, but can not RDM search the lamp, first check the signal amplifier, and then check whether the 2 and 3 lines of the signal line have poor contact.
 - All lamps must be set to DMX mode to ensure that there is only one host on the signal line;
- A 120 ohm impedance matching resistance must be inserted between terminals 2 and 3 of the terminal plug. When the signal line is relatively long, the signal reflection, which is conducive to